

**HYUNDAI**  
POWER PRODUCTS

# **CORDLESS CIRCULAR SAW**

## **HSC20V2A**

**ORIGINAL INSTRUCTIONS**

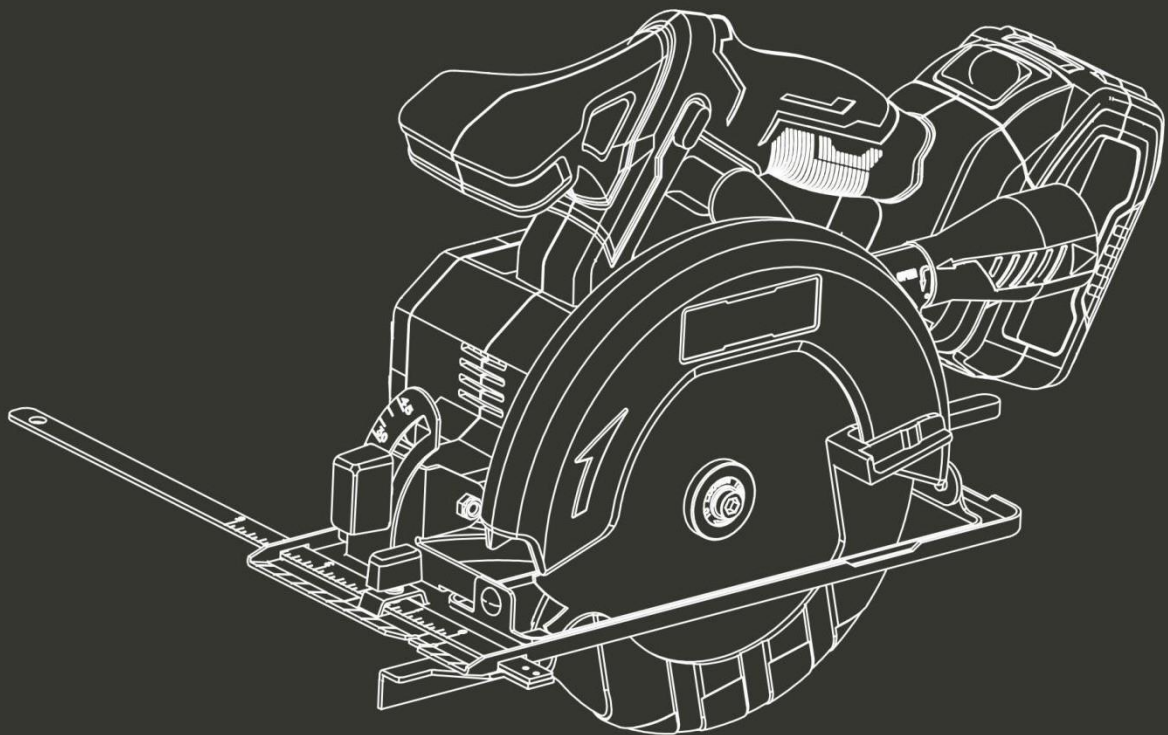

WARNING: Read thoroughly the instruction manual before use

# CONTENTS

1. INTENDED USE	3
2. SAFETY INSTRUCTIONS	3
3. YOUR PRODUCT	9
4. SPECIFICATIONS	11
5. ASSEMBLY	12
6. OPERATION	13
7. CLEANING, MAINTENANCE AND STORAGE	15
8. TROUBLESHOOTING	16
9. DISPOSAL	16
10. DECLARATION OF CONFORMITY	17
11. WARRANTY	18
12. PRODUCT FAILURE	19
13. WARRANTY EXCLUSIONS	20

# 1. INTENDED USE

This tool is designed to cut wood that will fit the machine. Only use saw blades suitable for the machine and do not use cutting discs.

# 2. SAFETY INSTRUCTIONS

## 2.1 GENERAL POWER TOOL SAFETY INFORMATION



**WARNING** Read all safety warnings, instructions, illustrations and specifications provided with this power tool. *Failure to follow all instructions listed below may result in electric shock, fire and/or serious injury.*

**Save all warnings and instructions for future reference.** *The term "power tool" in the warnings refers to your mains-operated (corded) power tool or battery-operated (cordless) power tool.*

### 1) Work area safety

**a) Keep work area clean and well lit.** *Cluttered or dark areas invite accidents.*

**b) Do not operate power tools in explosive atmospheres, such as in the presence of flammable liquids, gases or dust.** *Power tools create sparks which may ignite the dust or fumes.*

**c) Keep children and bystanders away while operating a power tool.** *Distractions can cause you to lose control.*

### 2) Electrical safety

**a) Power tool plugs must match the outlet. Never modify the plug in any way. Do not use any adapter plugs with earthed (grounded) power tools.** *Unmodified plugs and matching outlets will reduce risk of electric shock.*

**b) Avoid body contact with earthed or grounded surfaces, such as pipes, radiators, ranges and refrigerators.** *There is an increased risk of electric shock if your body is earthed or grounded.*

**c) Do not expose power tools to rain or wet conditions.** *Water entering a power tool will increase the risk of electric shock.*

**d) Do not abuse the cord. Never use the cord for carrying, pulling or unplugging the power tool. Keep cord away from heat, oil, sharp edges or moving parts.** *Damaged or entangled cords increase the risk of electric shock.*

**e) When operating a power tool outdoors, use an extension cord suitable for outdoor use.** *Use of a cord suitable for outdoor use reduces the risk of electric shock.*

**f) If operating a power tool in a damp location is unavoidable, use a residual current device (RCD) protected supply.** *Use of an RCD reduces the risk of electric shock.*

### 3) Personal safety

**a) Stay alert, watch what you are doing and use common sense when operating a power tool. Do not use a power tool while you are tired or under the influence of drugs, alcohol or medication.** *A moment of inattention while operating power tools may result in serious personal injury.*

**b) Use personal protective equipment. Always wear eye protection.** *Protective equipment such as dust mask, non-skid safety shoes, hard hat, or hearing protection used for appropriate conditions will reduce personal injuries.*

**c) Prevent unintentional starting. Ensure the switch is in the off-position connecting to power source and/or battery pack, picking up or carrying the tool.** *Carrying power tools with your finger on the switch or energizing power tools that have the switch on invites accidents.*

**d) Remove any adjusting key or wrench before turning the power tool on.** *A wrench or a key left attached to a rotating part of the power tool may result in personal injury.*

- e) **Do not overreach. Keep proper footing and balance at all times.** *This enables better control of the power tool in unexpected situations.*
- f) **Dress properly. Do not wear loose clothing or jewelry. Keep your hair, clothing and gloves away from moving parts.** *Loose clothes, jewelry or long hair can be caught in moving parts.*
- g) **If devices are provided for the connection of dust extraction and collection facilities, ensure these are connected and properly used.** *Use of dust collection can reduce dust-related hazards.*
- h) **Do not let familiarity gained from frequent use of tools allow you to become complacent and ignore tool safety principles.** *A careless action can cause severe injury within a fraction of a second.*

#### 4) Power tool use and care

- a) **Do not force the power tool. Use the correct power tool for your application.** *The correct power tool will do the job better and safer at the rate for which it was designed.*
- b) **Do not use the power tool if the switch does not turn it on and off.** *Any power tool that cannot be controlled with the switch is dangerous and must be repaired.*
- c) **Disconnect the plug from the power source and/or the battery pack from the power tool before making any adjustments, changing accessories, or storing power tools.** *Such preventive safety measures reduce the risk of starting the power tool accidentally.*
- d) **Store idle power tools out of the reach of children and do not allow persons unfamiliar with the power tool or these instructions to operate the power tool.** *Power tools are dangerous in the hands of untrained users.*
- e) **Maintain power tools. Check for misalignment or binding of moving parts, breakage of parts and any other condition that may affect the power tool's operation. If damaged, have the power tool repaired before use.** *Many accidents are caused by poorly maintained power tools.*
- f) **Keep cutting tools sharp and clean.** *Properly maintained cutting tools with sharp cutting edges are less likely to bind and are easier to control.*
- g) **Use the power tool, accessories and tool bits etc. in accordance with these instructions, taking into account the working conditions and the work to be performed.** *Use of the power tool for operations different from those intended could result in a hazardous situation.*
- h) **Keep handles and grasping surfaces dry, clean and free from oil and grease.** *Slippery handles and grasping surfaces do not allow for safe handling and control of the tool in unexpected situations.*

#### 5) Battery tool use and care

- a) **Recharge only with the charger specified by the manufacturer.** *A charger that is suitable for one type of battery pack may create a risk of fire when used with another battery pack.*
- b) **Use power tools only with specifically designated battery packs.** *Use of any other battery packs may create a risk of injury and fire.*
- c) **When battery pack is not in use, keep it away from other metal objects, like paper clips, coins, keys, nails, screws or other small metal objects, that can make a connection from one terminal to another.** *Shorting the battery terminals together may cause burns or a fire.*
- d) **Under abusive conditions, liquid may be ejected from the battery; avoid contact. If contact accidentally occurs, flush with water. If liquid contacts eyes, additionally seek medical help.** *Liquid ejected from the battery may cause irritation or burns.*
- e) **Do not use a battery pack or tool that is damaged or modified.** *Damaged or modified batteries may exhibit unpredictable behaviour resulting in fire, explosion or risk of injury.*
- f) **Do not expose a battery pack or tool to fire or excessive temperature.** *Exposure to fire or temperature above 130 °C may cause explosion.*

NOTE The temperature „130 °C“ can be replaced by the temperature „265 °F“.

- g) **Follow all charging instructions and do not charge the battery pack or tool outside the temperature range specified in the instructions.** *Charging improperly or at temperatures outside the specified range may damage the battery and increase the risk of fire.*

## 6) Service

**a) Have your power tool serviced by a qualified repair person using only identical replacement parts.**

*This will ensure that the safety of the power tool is maintained.*

**b) Never service damaged battery packs.** *Service of battery packs should only be performed by the manufacturer or authorized service providers.*

## 2.2 SPECIFIC SAFETY RULES

### DANGER:

- a) Keep hands away from cutting area and blade. Keep your second hand on auxiliary handle or motor housing.** If both hands are holding the saw, they cannot be cut by the blade.
- b) Do not reach underneath the workpiece.** The guard cannot protect you from the blade below the workpiece.
- c) Adjust the cutting depth to the thickness of the workpiece.** Less than a full tooth of the blade teeth should be visible below the workpiece.
- d) Never hold the workpiece in your hands or across your leg while cutting. Secure the workpiece to a stable platform.** *It is important to support the work properly to minimise body exposure, blade binding, or loss of control.*
- e) Hold power tool by insulated gripping surfaces when performing an operation where the cutting tool may contact hidden wiring or its own cord.** Contact with a “live” wire will also make exposed metal parts of the power tool “live” and shock the operator.
- f) When ripping always use a rip fence or straight edge guide.** This improves the accuracy of cut and reduces the chance of blade binding.
- g) Always use blades with correct size and shape (diamond versus round) of arbor holes.** Blades that do not match the mounting hardware of the saw will run eccentrically, causing loss of control.
- h) Never use damaged or incorrect blade washers or bolt.** The blade washers and bolt were specially designed for your saw, for optimum performance and safety of operation.

## 2.3 SPECIAL SAFETY REGULATIONS

Causes and operator prevention of kickback:

- Kickback is a sudden reaction to a pinched, bound or misaligned saw blade, causing an uncontrolled saw to lift up and out of the workpiece toward the operator;
- When the blade is pinched or bound tightly by the kerf closing down, the blade stalls and the motor reaction drives the unit rapidly back toward the operator;
- If the blade becomes twisted or misaligned in the cut, the teeth at the back edge of the blade can dig into the top surface of the wood causing the blade to climb out of the kerf and jump back toward the operator.
- Kickback is the result of saw misuse and/or in corrects operating procedures or conditions and can be avoided by taking proper precautions as given below.

- a) Maintain a firm grip with both hands on the saw and position your arms to resist kickback forces.** **Position your body to either side of the blade, but not in line with the blade.** *Kick back could cause the saw to jump backwards, but kickback forces can be controlled by the operator, if proper precautions are taken.*
- b) When blade is binding, or when interrupting a cut for any reason, release the trigger and hold the saw motionless in the material until the blade comes to a complete stop. Never attempt to remove the saw from the work or pull the saw backward while the blade is in motion or kickback may occur.** *Investigate and take corrective actions to eliminate the cause of blade binding.*
- c) When restarting a saw in the workpiece, center the saw blade in the kerf and check that saw teeth are not engaged into the material.** *If saw blade is binding, it may walk up or kickback from the*

workpiece as the saw is restarted.

- d) **Support large panels to minimize the risk of blade pinching and kickback.** Large panels tend to sag under their own weight. Supports must be placed under the panel on both sides, near the line of cut and near the edge of the panel.
- e) **Do not use dull or damaged blades.** Unsharpened or improperly set blades produce narrow kerf causing excessive friction, blade binding and kickback.
- f) **Blade depth and bevel adjusting locking levers must be tight and secure before making cut.** If blade adjustment shifts while cutting, it may cause binding and kickback.
- g) **Use extra caution when making a “plunge cut” into existing walls or other blind areas.** The protruding blade may cut objects that can cause kickback.

## 2.4 SAFETY INSTRUCTIONS FOR THE SAW

- a) **Check lower guard for proper closing before each use. Do not operate the saw if lower guard does not move freely and close instantly. Never clamp or tie the lower guard into the open position.** If saw is accidentally dropped, lower guard may be bent. Raise the lower guard with the retracting handle and make sure it moves freely and does not touch the blade or any other part, in all angles and depths of cut.
  - b) **Check the operation of the lower guard spring. If the guard and the spring are not operating properly, they must be serviced before use.** Lower guard may operate sluggishly due to damaged parts, gummy deposits, or a build-up of debris.
  - c) **Lower guard may be retracted manually only for special cuts such as “plunge cuts” and “compound cuts.” Raise lower guard by retracting handle and as soon as blade enters the material, the lower guard must be released.** For all other sawing, the lower guard should operate automatically.
  - d) **Always observe that the lower guard is covering the blade before placing saw down on bench or floor.** An unprotected, coasting blade will cause the saw to walk backwards, cutting whatever is in its path. Be aware of the time it takes for the blade to stop after switch is released.
- Use only saw blades recommended by the manufacturer, which conform to EN 847-1, if intended for wood and analogous materials.
  - Use only blade diameter(s) in accordance with the markings.
  - Only use blades for wood cutting.
  - Avoid overheating the blade tips
  - Wear a dust mask.
  - Do not use abrasives wheels

## 2.5 SAFETY INSTRUCTIONS FOR BATTERIES AND CHARGER

### Batteries

- Never attempt to open for any reason.
- Do not store in locations where the temperature may exceed 40°C (104°F).
- Charge only at ambient temperatures between 4°C and 40°C (39.2°F and 104°F).
- Charge only using the charger provided with the tool.
- Store your batteries in a cool dry place (5°C-20°C/41°F-68°F). Never store batteries in discharged state.
- It is better for Li-ion batteries to discharge and reload them regularly (at least 4 times a year). The ideal charge for long-term storage of your Li-ion battery is 40% of capacity.

- When disposing of batteries, follow the instructions given in the section “Protecting the environment”.
- Do not cause short circuits. If connection is made between the positive (+) and negative (-) terminal directly or via accidental contact with metallic objects, the battery is short circuited and an intense current will flow causing heat generation which may lead to casing rupture or fire.
- Do not heat. If batteries are heated to above 100°C (212°F), sealing and insulating separators and other polymer components may be damaged resulting in electrolyte leakage and/or internal short circuiting leading to heat generation causing rupture or fire. Moreover do not dispose of the batteries in fire, explosion and/or intense burning may result.
- Under extreme conditions, battery leakage may occur. When you notice liquid on the battery, proceed as follows:
  - ✓ Carefully wipe the liquid off using a cloth. Avoid skin contact.
  - ✓ In case of skin or eye contact, follow the instructions below:
    - Immediately rinse with water. Neutralize with a mild acid such as lemon juice or vinegar.
    - In case of eye contact, rinse abundantly with clean water for at least 10 minutes. Consult a physician.



**Fire hazard! Avoid short-circuiting the contacts of a detached battery. Do not incinerate the battery.**

## Charger













- Use the charger provided with the tool only to charge the battery.
- Never attempt to charge non-rechargeable batteries.
- Have defective cords replaced immediately.
- Do not expose to water.
- Do not open the charger.
- Do not probe the charger.
- The charger is intended for indoor use only.
- This charger can be used by children aged from 8 years and above and persons with reduced physical, sensory or mental capabilities or lack of experience and knowledge if they have been given supervision or instruction concerning use of the appliance in a safe way and understand the hazards involved.



- Children shall not play with the appliance. Cleaning and user maintenance shall not be made by children without supervision.
- If the supply cord is damaged, it must be replaced by the manufacturer, its service agent or similarly qualified persons in order to avoid a hazard.

**CAUTION: Do not recharge non-rechargeable batteries.**

## 2.6 SYMBOLS

	To reduce the risk of injury, the user must read and understand this manual before using this product.
	Wear ear protectors. Exposure to noise can cause hearing loss.
	Wear eye protection.
	Wear respiratory protection.
	Wear protective gloves
	Class II, double isolation(only for charger)
	Do not dispose of old appliances with domestic rubbish
	Ne pas exposer le chargeur ni la batterie à l'eau.
	Do not incinerate the battery or charger.
	Ambient temperature of 40 ° C max. (only for the battery)
	Use the battery and charger Indoor use only.
	Recycling



### 3. YOUR PRODUCT

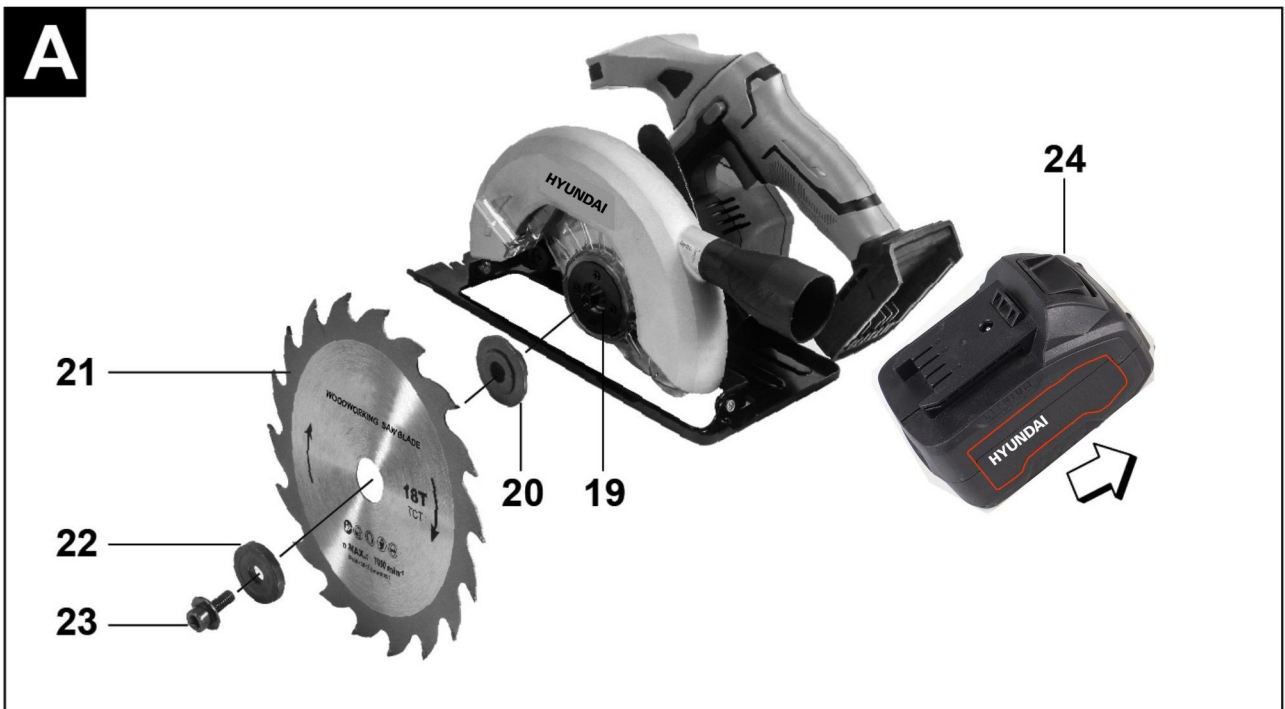
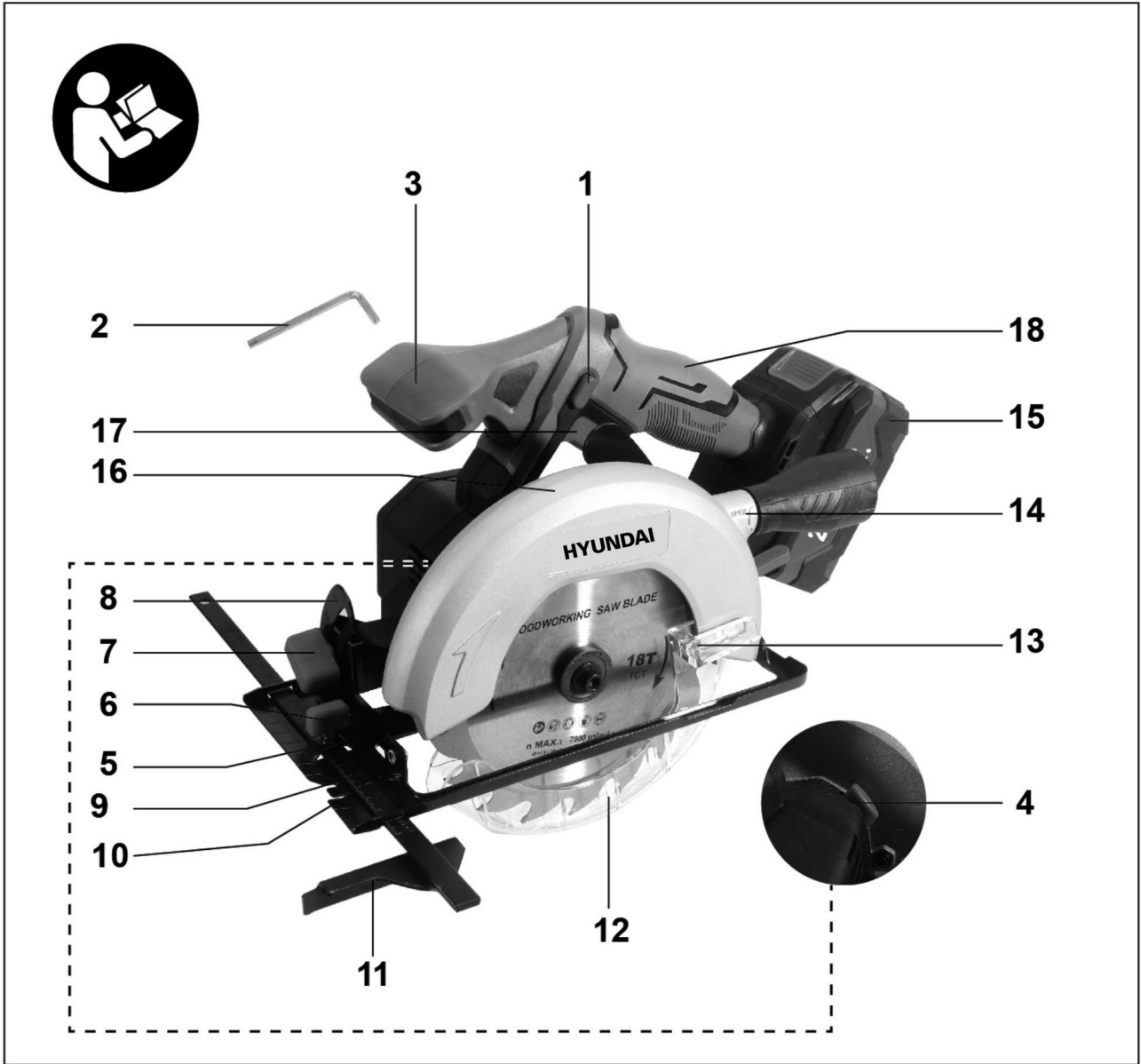

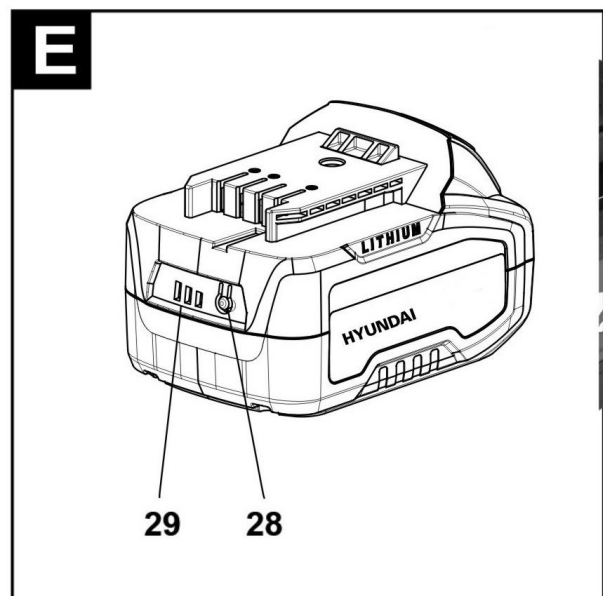
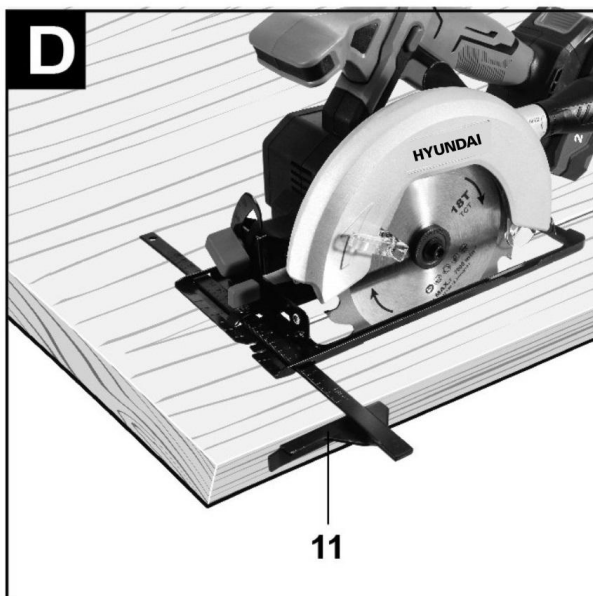
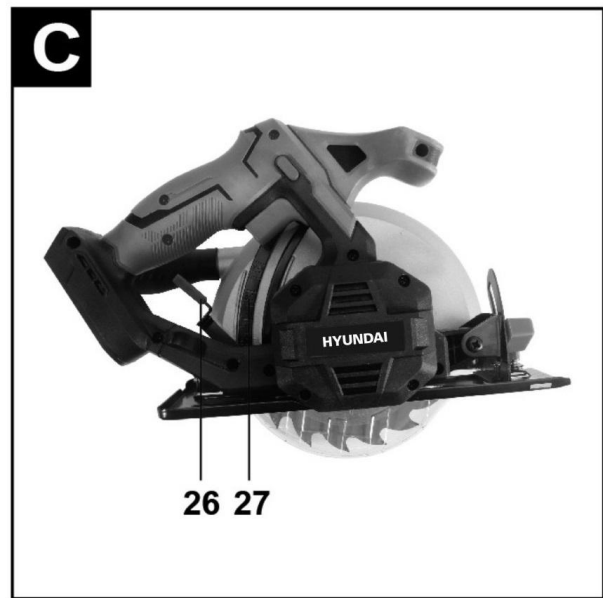
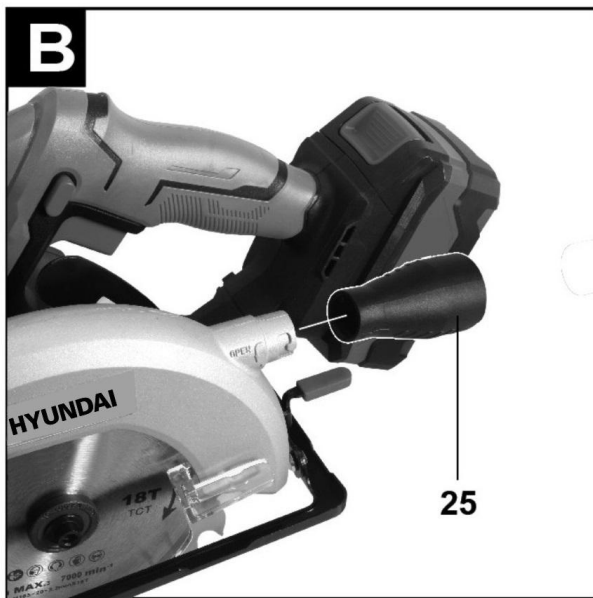

- (1) Lock button for on/off switch
- (2) Hex key
- (3) Auxiliary handle (insulated gripping surface)
- (4) Spindle lock button
- (5) Base plate
- (6) Wing bolt for parallel guide
- (7) Wing bolt for mitre/bevel angle preselection
- (8) Scale for mitre/bevel angles
- (9) Cut mark 45°
- (10) Cut mark 0°
- (11) Parallel guide
- (12) Retracting blade guard
- (13) Adjusting lever for retracting blade guard
- (14) Chip ejector
- (15) Battery
- (16) Protective guard
- (17) On/off switch
- (18) Handle (insulated gripping surface)
- (19) Saw spindle
- (20) Mounting flange
- (21) Circular saw blade
- (22) Clamping flange
- (23) Clamping bolt with washer
- (24) Battery release button
- (25) Dust extraction adapter
- (26) Clamping lever for cutting depth preselection
- (27) Cutting depth scale
- (28) Button for battery charge indicator
- (29) Battery charge indicator

## 4. SPECIFICATIONS

Power supply	20 V d.c.
No Load Speed	4300 min <sup>-1</sup>
Dia. of saw blade (mm)	Ø165mm
Max cutting depth	52mm (90°), 36mm (45°)
Miter angle	0 °- 45 °
Saw blade	Φ165xΦ20x2.0x24T, max 7900/min
Charger type	HSC20V2A Input 100-240V~ 50-60Hz, 0.4A; Output 20V d.c., 0.5A 10W
Battery type	HSC20V2A  20V d.c. 2.0Ah, Lithium-ion 5Li-on cells
Charging time	Approx: 4 hours
Acoustic pressure level LpA	86.4 dB(A) , K = 3 dB(A)
Acoustic power level LwA	97.4 dB(A) , K = 3 dB(A)
aw (Vibration)	Main handle: 1,970 m/s <sup>2</sup> (K= 1.5 m/s <sup>2</sup> )  Auxiliary handle: 2,294 m/s <sup>2</sup> (K= 1.5 m/s <sup>2</sup> )
Weight (Not include battery pack)	2.45kg

### **Information**

- The declared vibration total value has been measured in accordance with a standard test method and may be used for comparing one tool with another;
- The declared vibration total value may also be used in a preliminary assessment of exposure.

### **Warning**

- that the vibration emission during actual use of the power tool can differ from the declared total value depending on the ways in which the tool is used;
- of the need to identify safety measures to protect the operator that are based on an estimation of exposure in the actual conditions of use (taking account of all parts of the operating cycle such as the times when the tool is switched off and when it is running idle in addition to the trigger time).

Wear hearing protection.

# 5. ASSEMBLY



**WARNING !** Remove the battery pack before assembly. The tool should not use any abrasive wheel.



Wear gloves to avoid the risk of injury.

## 5.1 INSERTING/CHANGING THE CIRCULAR SAW BLADE

- Only use saw blades that match the specifications given in this user guide.
- The permitted speed of the application tool must be at least equal to the maximum speed marked on the power tool. If accessories run faster than their rated speed, they may break and fly off.
- Do not use abrasive wheels as the application tool under any circumstances.

### Removing the saw blade (see figure A)

To change tools, we recommend that you place the power tool down on the front side of the motor housing.

- Press and hold the spindle lock button.
- Do not press the spindle lock button while the saw spindle is moving. The power tool may become damaged if this happens.
- Use the hex key to undo the clamping bolt in rotational direction.
- Swing the retracting blade guard back and hold on to it firmly.
- Remove the clamping flange and the saw blade from the saw spindle.

### Fitting the saw blade (see figure A)

To change tools, we recommend that you place the power tool down on the front side of the motor housing.

- Clean the saw blade and all the clamping elements to be fitted.
- Swing the retracting blade guard back and hold on to it firmly.
- Place the saw blade on the mounting flange. The cutting direction of the teeth (direction of the arrow on the saw blade) must match the rotational direction of the arrow on the retracting blade guard.
- Attach the clamping flange and screw in the clamping bolt in rotational direction. Ensure that the mounting flange and clamping flange are installed in the correct position.
- Press and hold the spindle lock button.
- Use the hex key to tighten the clamping bolt in rotational direction. The tightening torque should be 6-9 Nm.

### Dust/chip extraction

The dust from materials such as lead paint, some types of wood, minerals and metal can be harmful to human health. Touching or breathing in this dust can trigger allergic reactions and/or cause respiratory illnesses in the user or in people in the near vicinity.

Certain dust, such as oak or beeth dust are classified as carcinogenic, especially in conjunction with wood treatment additives (chromate, wood preservative). Materials containing asbestos may only be machined by specialists.

- Use a dust extraction system that is suitable for the material wherever possible.
- Provide good ventilation at the workplace.
- It is advisable to wear a P2 filter class breathing mask.

The regulations on the material being machined that apply in the country of use must be observed.

- Avoid dust accumulation at the workplace. Dust can easily ignite.

### Fitting the dust extraction adapter (see figure B)

Push the dust extraction adapter onto the chip ejector until it clicks into place.

# 6. OPERATION

## 6.1 CHARGING THE BATTERY PACK

**IMPORTANT:** The battery pack is not fully charged at the factory.

**Before attempting to charge them, thoroughly read all of the safety instructions.**

- 1) To assure that the charger you use are applicable to the battery pack.
- 2) Insert the charger into 100-240V~,50-60Hz outlet. The indicator light (31) become to red light to show the power is connected.
- 3) Insert the battery(15) into the slot of charger(30). Make sure the contact with the charger is correct.
- 4) The indicator light (31) become to green and flash when charging.
- 5) When fully charged The indicator light (31) become to green light.

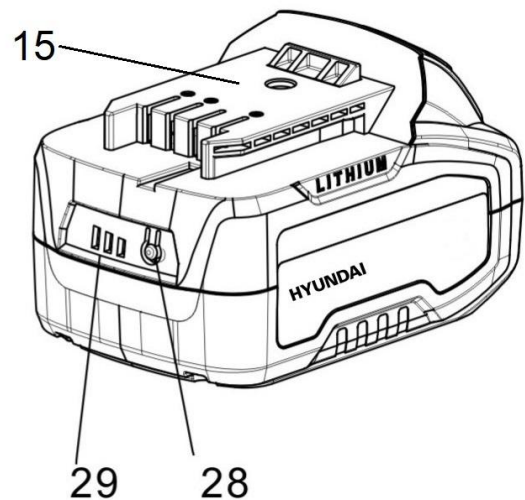
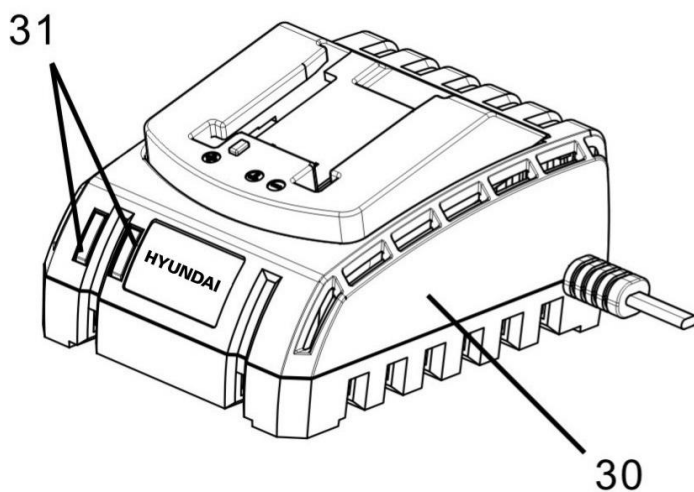

- 6) Frequently monitor the charger and battery pack while connected.
- 7) Unplug the charger and disconnect it from the battery pack when finished.
- 8) Allow the battery pack to cool completely before using it.
- 9) Store the charger and battery pack indoors, out of reach of children.



Note: If the battery does not fit properly, disconnect it and confirm that the battery pack is the correct model for this charger as shown on the specification chart. Do not charge any other battery pack or any battery pack that does not securely fit the charger.



**NOTE:** If battery is hot after continuous use in the tool, allow it to cool down to room temperature before charging. This will extend the life of your batteries.



**NOTE:** Remove battery pack from charger stand which use your thumb or fingers, press the battery's release button in and pull the battery pack off at the same time.

### Battery capacity indicator

There are battery capacity indicators on the battery pack; you can check the capacity status of the battery if you squeeze the button . Before using the machine, please press switch trigger to check if the battery is full enough for properly working.



**WARNING:** Before making any adjustments ensure the drill is switched off with the direction of rotation selector in the center position.

1. Remove the battery: press the battery release latch in and at the same time pull the battery pack off.
2. To insert the battery, push the battery pack onto the contacts of the tool.

## 6.2 OPERATING MODES

- **Remove the battery before carrying out any work on the power tool.**

### Setting the cutting depth (see figure C)

- **Adapt the cutting depth to the thickness of the workpiece.** A space of less than the height of one full tooth should be visible under the workpiece.

Loosen the clamping lever. For a smaller cutting depth, pull the saw away from the base plate; for a larger cutting depth, push the saw towards the base plate. Adjust the desired cutting depth at the cutting-depth scale. Re-tighten the clamping lever.

The clamping force of the clamping lever can be readjusted. To do so, unscrew the clamping lever and retighten it in a position offset by at least 30° in an anticlockwise direction.

### Setting the mitrebevel angle

We recommend that you place the power tool down on the front side of the protective guard. Loosen the wing bolt. Swivel the saw to the side. Set the required mitre angle on the scale retighten the wing bolt.

**Note:** When making mitre cuts, the cutting depth is less than the value shown on the cutting depth scale.

#### Cut marks

The 0° cut mark indicates the position of the saw blade when making a right-angled cut.

The 45° cut mark indicates the position of the saw blade when making a 45° cut.

### Start-up

Inserting the battery

- **Use only original lithium-ion batteries with the voltage stated on the type plate of your power tool.** Using other batteries can lead to injuries and pose a fire hazard.

Slide the charged battery into the foot of the power tool from the front. Press the battery fully into the foot until the red stripe is no longer visible and the battery is securely locked.

### Switching on/off

To start the power tool, first press the lock-off switch then press and hold the on/off switch.

To switch off the power tool, release the on/off switch.

**Note:** For safety reasons, the on/off switch cannot be locked; it must remain pressed during the entire operation.

### Protection Against Deep Discharging

The lithium-ion battery is protected against deep discharge by the Electronic Cell Protection (ECP). When the battery is discharged, the power tool is switched off by means of a protective circuit: The application tool no longer rotates.

### Practical advice

The width of cut varies depending on the saw blade used. Protect saw blades against shock and impact.

Guide the power tool evenly, pushing it gently in the cutting direction. Applying too much pressure to the power tool when moving it in the cutting direction significantly reduces the service life of the application tools and can damage the power tool.

The sawing performance and the quality of the cut essentially depend on the condition and the tooth shape of the saw blade. This is why you should only use sharp saw blades that are suitable for the material being machined.

## **Sawing wood**

Choosing the right saw blade depends on the wood type, wood quality and whether cuts with or against the grain are required.

Making cuts in spruce with the grain produces long, spiral- shaped chips.

Beech and oak dust is especially detrimental to health. Therefore, work only with dust extraction.

### **Sawing with a parallel guide (see figure D)**

The parallel guide allows you to make precise cuts along the edge of a workpiece and cut strips with the same dimensions.

Recommendations for Optimal Handling of the Battery

Protect the battery against moisture and water.

Only store the battery within a temperature range of -20 to 50 °C. Do not leave the battery in your car in the summer, for example. Occasionally clean the ventilation slots on the battery using a soft brush that is clean and dry.

A significantly reduced operating time after charging indicates that the battery has deteriorated and must be replaced. Follow the instructions on correct disposal.

# **7. CLEANING, MAINTENANCE AND STORAGE**

## **7.1 CLEANING**

- a) Keep the ventilation slots free of dust and dirt to prevent overheating.
- b) Regularly clean the circular saw housing with a soft cloth, preferably after each use. If the dirt does not come off, use a soft cloth dampened with soapy water.
- c) Never use solvents such as gasoline, alcohol, ammonia water, etc. These solvents can damage plastic parts

## **7.2 MAINTENANCE**

- a) The circular saw has been designed to operate over a long period of time with minimal maintenance. Continued satisfactory operation depends on proper maintenance and regular cleaning.
- b) The circular saw should only be repaired by an authorized service center.

## **7.3 STORAGE**

- a) Thoroughly clean the circular saw and its accessories before putting it away.
- b) Store the circular saw out of the reach of children in a stable and secure place.



## 8. TROUBLESHOOTING

Problems	Causes	Solutions
Cannot start	Battery pack is not properly installed	Remove and reinsert battery pack
	The battery is discharged	Charge the battery
	Internal damage or wear, example the engine is damaged	Repair by a repair center approved maintenance
Can only run slowly	The battery is not charged	Charge the battery
	The battery wears out	Replace the battery with a new battery
Cannot cut effectively	The saw blade is dull	Change the saw blade
Big noise or abnormal sound	Internal damage or wear	Repair by a repair center approved maintenance
Overheated	Air vents are blocked	Clean dust from air vents
	The saw blade is dull	Change the saw blade
	The circular saw operates for too long	Switch off the circular saw and allow it to cool.

## 9. DISPOSAL

Electric power tools, as well as their accessories and packaging, must each be able to follow an appropriate recycling pathway. Only for the countries of the European Union:



Do not throw away your electrical appliance with the household waste! In accordance with the European Directive 2012/19/EU on waste electrical and electronic equipment and its implementation in national laws, power tools that can no longer be used must be separated and follow an appropriate recycling pathway.

### BATTERY PACK



**Li-ion**

This product contains Li-ion. To preserve natural resources, please recycle or dispose of batteries properly. Local, state or federal laws may prohibit disposal of Li-ion batteries in ordinary trash. Consult your local waste authority for information regarding available recycling and/or disposal options.

# 10. DECLARATION OF CONFORMITY



**BUILDER SAS**

**32, rue Aristide Bergès - ZI 31270 Cugnaux - France**, declares that,

Product: CORDLESS CIRCULAR SAW

Trade mark: HYUNDAI

Model: HSC20V2A

Serial number: **20211164350-20211164749**

is in conformity with the essential requirements and other relevant provisions of the applicable European Directives, based on the application of European harmonized standards. Any unauthorized modification of the apparatus voids this declaration.

European Directives (including, if applicable, their amendments up to the date of signature);  
Rohs directive 2011/65/EU + (EU) 2015/863

Directive Machine 2006/42/EC

Directive EMC 2014/30/UE

LVD Directive 2014/35/UE

European harmonized standards (including, if applicable, their amendments up to the date of signature);

EN62841-1: 2015; EN62841-2-5: 2014

EN55014-1 : 2017+A11:2020; EN55014-2 : 2015

EN62233:2008

EN60335-2-29:2004+A2:2010+A11:2018

EN60335-1:2012+A11:2014+A13:2017+A1:2019+A2:2019+A14:2019

EN55014-1 : 2017

EN55014-2 : 2015

EN61000-3-2:2014

EN61000-3-3:2013

Cugnaux, 16/09/2021

Philippe MARIE / PDG

Responsible of the technical file: Mr Olivier Patriarca

## 11. WARRANTY

# HYUNDAI

## WARRANTY

The manufacturer guarantees the product against defects in material and workmanship for a period of 2 years from the date of the original purchase. The warranty only applies if the product is for household use. The warranty does not cover breakdowns due to normal wear and tear.

The manufacturer agrees to replace parts identified as defective by the designated distributor. The manufacturer does not accept responsibility for the replacement of the machine, in whole or in part, and/or ensuing damage.

### The warranty does not cover breakdowns due to:

- insufficient maintenance.
- abnormal assembly, adjustment or operations of the product.
- parts subject to normal wear and tear.

### The warranty does not extend to:

- shipping and packaging costs.
- using the tool for a purpose other than that for which it was designed.
- the use and maintenance of the machine done in a manner not described in the user manual.

Due to our policy of continuous product improvement, we reserve the right to alter or change specifications without notice. Consequently, the product may be different from the information contained therein, but a modification will be undertaken without notice if it is recognized as an improvement of the preceding characteristic.

### READ THE MANUAL CAREFULLY BEFORE USING THE MACHINE.

When ordering spare parts, please indicate the part number or code, you can find this in the spare parts list in this manual. Keep the purchase receipt; without it, the warranty is invalid. To help you with your product, we invite you to contact us by phone or via our website:

- **+33 (0)9.70.75.30.30**
- **<https://services.swap-europe.com/contact>**

You must create a "ticket" via the web platform.

- Register or create your account.
- Indicate the reference of the tool.
- Choose the subject of your request.
- Describe your problem.
- Attach these files: invoice or sales receipt, photo of the identification plate (serial number), photo of the part you need (for example: pins on the transformer plug which are broken).



# 12. PRODUCT FAILURE

## WHAT TO DO IF MY MACHINE BREAKS DOWN?

### If you bought your product in a store:

a) Empty the fuel tank if your product has one.

b) Make sure that your machine is complete with all accessories supplied, and clean! If this is not the case, the repairer will refuse the machine.

Go to the store with the complete machine and with the receipt or invoice.

### If you bought your product on a website:

a) Empty the fuel tank if your product has one..

b) Make sure that your machine is complete with all accessories supplied, and clean! If this is not the case, the repairer will refuse the machine.

c) Create a SWAP-Europe service ticket on the site: <https://services.swap-europe.com> When making the request on SWAP-Europe, you must attach the invoice and the photo of the nameplate (serial number).

d) Contact the repair station to make sure it is available before dropping off the machine.

Go to the repair station with the complete machine packed, accompanied by the purchase invoice and the station support sheet downloadable after the service request is completed on the SWAP-Europe site

For machines with engine failure from manufacturers BRIGGS & STRATTON, HONDA and RATO, please refer to the following instructions.

Repairs will be done by approved engine manufacturers of these manufacturers, see their site:

- <http://www.briggsandstratton.com/eu/fr>
- <http://www.honda-engines-eu.com/fr/service-network-page;jsessionid=5EE8456CF39CD572AA2AEEDFD290CDAE>
- <https://www.rato-europe.com/it/service-network>

**Please keep your original packaging to allow for after-sales service returns or pack your machine with a similar cardboard box of the same dimensions.**

**For any question concerning our after-sales service you can make a request on our website <https://services.swap-europe.com>**

**Our hotline remains available at +33 (9) 70 75 30 30.**



# 13. WARRANTY EXCLUSIONS

## THE WARRANTY DOES NOT COVER:

- Start-up and setting up of the product.
- Damage resulting from normal wear and tear of the product.
- Damage resulting from improper use of the product.
- Damage resulting from assembly or start-up not in accordance with the user manual.
- Breakdowns related to carburetion beyond 90 days and fouling of carburetors.
- Periodic and standard maintenance events.
- Actions of modification and dismantling that directly void the warranty.
- Products whose original authentication marking (brand, serial number) has been degraded, altered or withdrawn.
- Replacement of consumables.
- The use of non-original parts.
- Breakage of parts following impacts or projections.
- Accessories breakdowns.
- Defects and their consequences linked to any external cause.
- Loss of components and loss due to insufficient screwing.
- Cutting components and any damage related to the loosening of parts.
- Overload or overheating.
- Poor power supply quality: faulty voltage, voltage error, etc.
- Damages resulting from the deprivation of enjoyment of the product during the time necessary for repairs and more generally the costs related to the immobilization of the product.
- The costs of a second opinion established by a third party following an estimate by a SWAP-Europe repair station
- The use of a product which would show a defect or a breakage which was not the subject of an immediate report and/or repair with the services of SWAP-Europe.
- Deterioration linked to transport and storage\*.
- Launchers beyond 90 days.
- Oil, petrol, grease.
- Damages related to the use of non-compliant fuels or lubricants.

\* In accordance with transport legislation, damage related to transport must be declared to carriers within 48 hours maximum after observation by registered letter with acknowledgement of receipt.

This document is a supplement to your notice, a non-exhaustive list.

**Attention:** all orders must be checked in the presence of the delivery person. In case of refusal by the delivery person, it you must simply refuse the delivery and notify your refusal.

**Reminder:** the reserves do not exclude the notification by registered letter with acknowledgement within 72 hours.

### Information:

Thermal devices must be wintered each season (service available on the SWAP-Europe site). Batteries must be charged before being stored.

**HYUNDAI**  
POWER PRODUCTS

**For Inquiries, please contact:**

BUILDER SAS  
32, Rue Aristide Bergès Z1 31270 Cugnaux, France  
Tél.: +33(0)5.34.502.502 Fax : +33(0)5.34.502.503  
<http://www.hyundaipower-fr.com/>  
Fabriqué en République Populaire de Chine(PRC)